

Mi Robot Vacuum User Manual

Read this manual carefully before use, and retain it for future reference





Safety Information

Restrictions

- This product is designed for indoor floor cleaning only, please do not use it outdoors (such as an open-ended terrace), on any surface instead of the ground (such as a sofa), or in a commercial or industrial environment
- Please do not use the product on any elevated surface without barriers (such as the floor of a loft, an open-ended terrace and the surface of furniture)
- Please do not use the product when the temperature is higher than 40 or lower than 4, or there is any liquid or sticky substance on the floor
- Before using the product, please put aside wires on the floor to avoid them being dragged around when the cleaner is working
- To prevent the cleaner from being blocked whilst it is working and your valuables from any damage from slight crashes. Please clean up fragile objects and odds and ends on the floor before switching on the cleaner (such as vases and plastic bags)
- This appliance is not intended for use by persons (including children) with reduced

Safety Information

physical, sensory or mental capabilities, or lack of experience and knowledge, unless they have been given supervision or instruction concerning use of the appliance by a person responsible for their safety. Children should be supervised to ensure that they do not play with the appliance (CB)

- This appliance can be used by children aged from 8 years and above and persons with reduced physical, sensory or mental capabilities or lack of experience and knowledge if they have been given supervision or instruction concerning use of the appliance in a safe way and understand the hazards involved. Children shall not play with the appliance. Cleaning and user maintenance shall not be made by children without supervision (EU)
- Please keep the main brush cleaning tools out of reach of children
- Do not place any object (including children and pets) on the cleaner, no matter whether it is working or not
- Keep hair, loose clothing, fingers, and all parts of body away from openings and moving parts

Safety Information

- Do not use the cleaner on any burning object (such as a burning cigarette butt)
- Do not use the cleaner on plush carpets (the cleaner might not work well on some dark-colored carpets either)
- Do not use the cleaner to clean hard or sharp objects (such as decoration wastes, glass and nails)
- Do not carry the cleaner by the cap on the distance laser sensor, the cover on the main unit or the collision buffer
- The appliance must be switched off and the plug must be removed from socket -outlet before cleaning or maintaining the appliance
- Do not use a wet piece of cloth or any liquid to clean any part of the product
- Do not use the mopping module on carpets
- Please use the product according to the manual. Any loss or damage caused from improper use will be borne by the user

Safety Information

Battery and Charging

WARNING

- For the purposes of recharging the battery, only use the detachable supply Unit Roborock CDZ05RR provided with this appliance
- Do not arbitrarily dismantle, repair or modify the battery or dock charger
- Please keep the dock charger away from heat (such as heating plates)
- The battery must be removed from the appliance before it is scrapped
- The appliance must be disconnected from the supply mains when removing the battery
- The battery is to be disposed of safely. Please do not discard waste batteries. Leave them to a professional recycling organization
- Do not wipe or clean the chargers shrapnel with a piece of wet cloth or wet hands

Safety Information

- If the supply cord is damaged, it must be replaced by the manufacturer, its service agent or similarly qualified persons in order to avoid a hazard
- Please make sure the cleaner is powered off in shipment and original packaging is advised
- If left unused for a long period, please store the cleaner in a cool and dry place after having it fully charged and switched off, charge it at least every three months to avoid the battery being over discharged

Laser Safety

The laser distance sensor of this product meets the standards for Class I Laser Products in IEC 60825-1:2014 and will not generate hazardous laser radiation

WEEE Information

Correct Disposal of this product . This marking indicates that this product should not be disposed with other household wastes throughout the EU. To prevent possible harm to the environment or human health from uncontrolled waste disposal, recycle it responsibly to promote the sustainable reuse of material resources. To return your used device, please use the return and collection systems or contact the retailer where the product was purchased. They can take this product for environmental safe recycling.

Korrekte Entsorgung dieses Produkts Innerhalb der EU weist dieses Symbol darauf hin, dass dieses Produkt nicht über den Hausmüll entsorgt werden darf. Altgeräte enthalten wertvolle recyclingfähige Materialien, die einer Wiederverwertung zugeführt werden sollten und um der Umwelt bzw. der menschlichen Gesundheit nicht durch unkontrollierte Müllbeseitigung zu schaden. Bitte entsorgen Sie Altgeräte deshalb über geeignete Sammelsysteme oder senden Sie das Gerät zur Entsorgung an die Stelle, bei der Sie es gekauft haben. Diese wird dann das Gerät der stofflichen Verwertung zuführen.



Warranty Information

The manufacturer provides warranty in accordance with the legislation of the customer's own country of residence, with a minimum of 1 year, starting from the date on which the appliance is sold to the end user.

The warranty only covers defects in material or workmanship.

The repairs under warranty may only be carried out by an authorized service centre. When making a claim under the warranty, the original bill of purchase (with purchase date) must be submitted.

The warranty will not apply in cases of:

Normal wear and tear

Incorrect use, e.g. overloading of the appliance, use of non-approved accessories

Use of force, damage caused by external influences

Damage caused by non-observance of the user manual, e.g. connection to an unsuitable mains supply or non-compliance with the installation instructions

Partially or completely dismantled appliances

Thank you for choosing Mi Robot Vacuum.

Mi Robot Vacuum is an intelligent cleaner outfitted with a high-precision laser distance sensor that can create a map of your home and calculate a precise cleaning route as it goes. It works its way methodically around your home and automatically navigates back to the charging dock once it gets the household chore done. You can view the map and cleaning status in real time, set a schedule and command the vacuum on your phone.

Technology is changing our life. From now on, you and your family will be freed from the boring household chores and start enjoying life.

Product Overview

Main unit

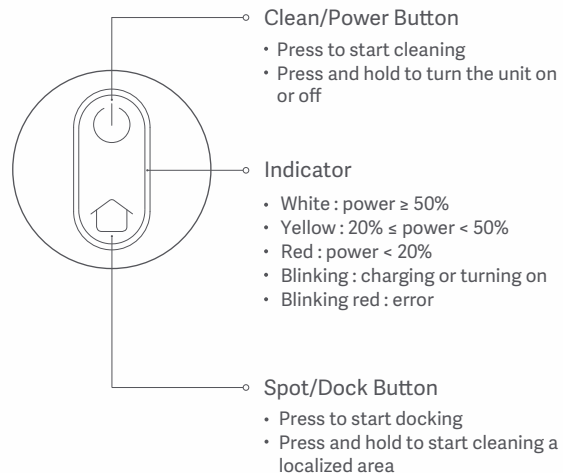
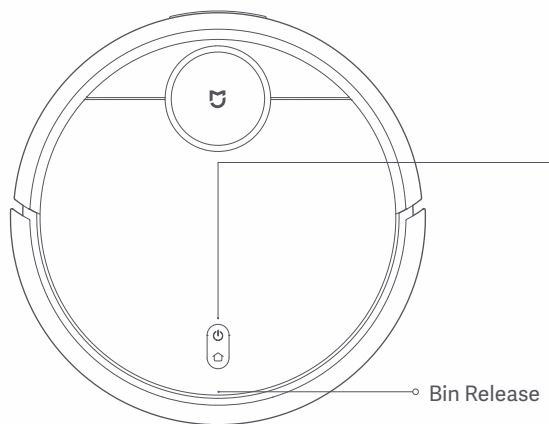

Accessories

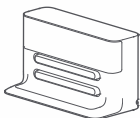

Charging Dock



Main Brush Cleaner

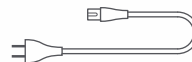

Power Cord

Product Overview

Main unit

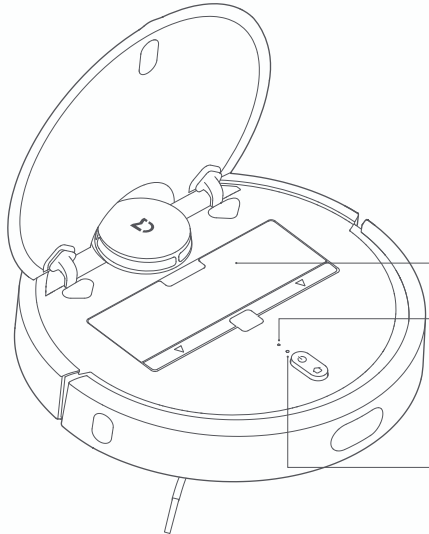

◦ Wi-Fi Indicator
Slow blinking : to be connected
Fast blinking : connecting
Solid light : Wi-Fi connected

◦ Reset Button

Dust Bin

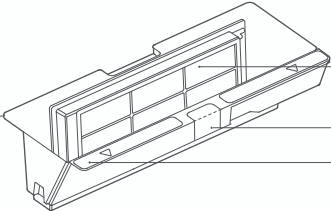

◦ Filter
◦ Bin Clip
◦ Bin Cover

Product Overview

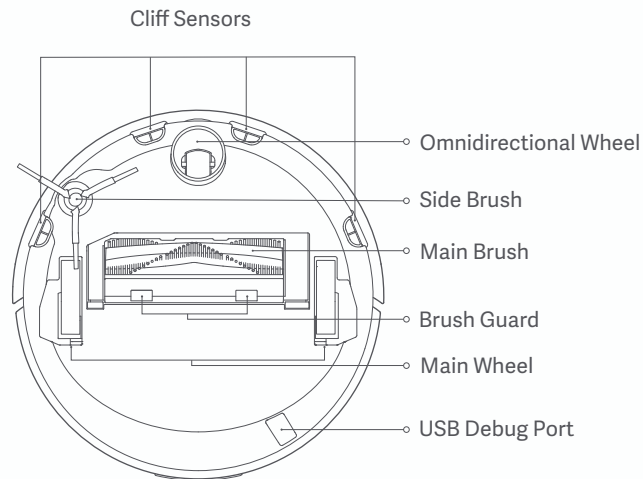
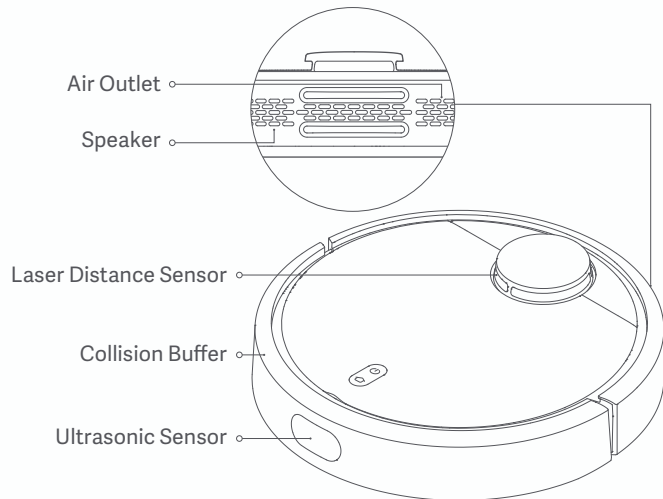

Installing

- 1 Connect the power cord, and put the excess cord back in the box.

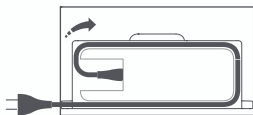

Note: The Unit may inadvertently tug or pull on the power cord if it is hanging off the ground, which could cut off power to the Charging Dock

- 2 Place the Charging Dock on level ground against a wall and connect it to the power

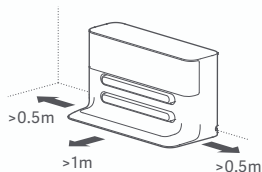

Note: Ensure there is 0.5 meters or more space on either side of the Charging Dock and more than 1 in front

- 3 Turn the unit on and recharge

Press and hold the button  to turn it on. Wait for the indicator to light up and then charge the unit by placing it on the Charging Dock.

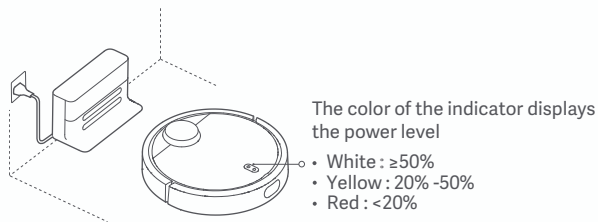

Note: It may not turn on with insufficient power. Please place the unit directly on the charging dock.

- 4 Connect the Mi Home App (this step can be skipped)

Scan the QR code or go to App Store to download the Mi Home App.

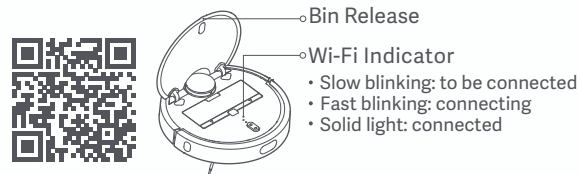



Note: See 'Resetting the Wi-Fi' in the 'User Manual' if your phone is unable to connect to the device after trying several times

- 5 Start cleaning

When the unit's indicator turns from pulsing white light to solid light, it shows that it is fully charged. Press the button  or command from Mi Home App to start cleaning.

Instructions

Turning on/off

Press and hold the button  to turn on the unit. The indicator light will go on, and the unit will enter standby mode. When the unit is stationary, press and hold the button  to turn it off, and the cleaning will be finished.

Note: You cannot turn the Unit off when it is charging

Cleaning

Press the button  to start cleaning

Press any button to pause the unit when it is cleaning

Note:

- The unit cannot start cleaning without sufficient power. Recharge the device before cleaning.
- The Unit will automatically return to the Charging Dock to charge when it runs low on power over the course of cleaning. It will automatically return and continue cleaning where it left off after charging
- Please tidy up any cables lying on the ground before cleaning (including the Charging Dock power cable itself) to prevent the unit from catching on any cables in the course of cleaning which might shut down any electrical appliances or cause damage to the objects or cables
- The device will clean the area twice by default if it completes the cleaning process in less than 10 minutes

Charging

Auto Mode: The Unit will automatically return to the Charging Dock to recharge after it finishes cleaning
Manual Mode: Press the button  to start charging when the unit is in Paused Mode. The indicator light will gently pulse while the unit is charging

Note: The unit will automatically return to its original location if it cannot locate the charging dock. You will then need to place the main unit on the charging dock manually to recharge it.

Cleaning Methods

The Unit will intelligently scan and map out its area being activated. It will clean along edges and walls first and then figure out a cleaning route that covers the entire area in Z-shaped patterns. It will methodically clean each zone it maps in a very comprehensive, methodical and highly efficient manner. The Unit will automatically return to the charging dock to recharge after cleaning is finished

Instructions

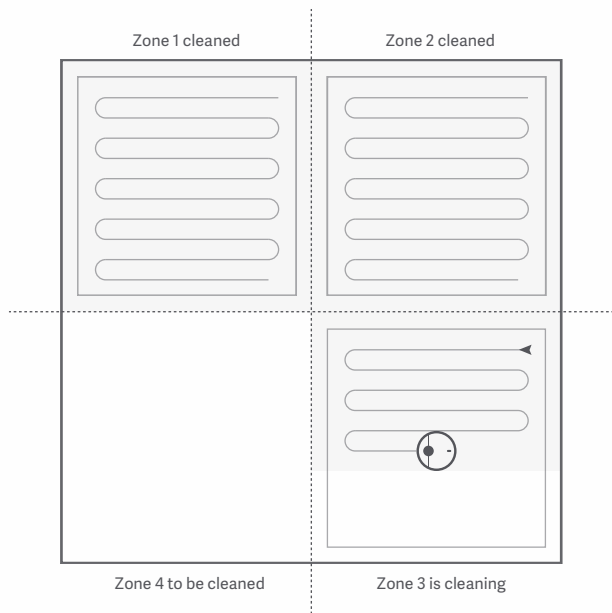

Local Cleaning

Press and hold the button  to activate local cleaning when the unit is awaiting instructions or paused. Use this mode to clean a 1.5×1.5 meter square-shaped area directly around the device. The main unit will automatically return to its original location afterwards and cease working.

Note: Activating local cleaning while the unit is paused will discontinue whatever cleaning it is currently doing

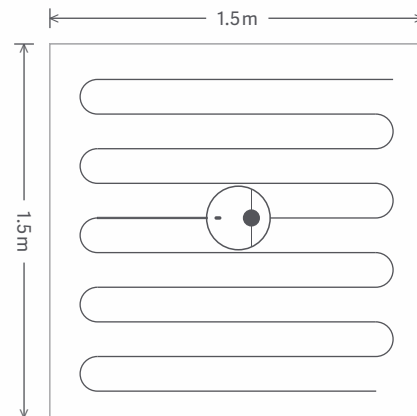

Instructions

Pausing

Press any buttons while the unit is operating to pause it. Press the button  to continue cleaning and press the button to return the unit to the charging dock and conclude its current cleaning operations.

Note: Recharging the unit on the charging dock when it is currently paused will finish its current cleaning operations.

Fault Status

The indicator light will start blinking red followed by a voice prompt whenever a problem occurs as the unit is working

Note:

The unit will go to sleep if no actions have been taken for 10 minutes after the unit has entered fault status.

Placing the device on the charging dock while the unit is in fault status will end its current cleaning operations.

Sleep

The unit will automatically go to sleep after 10 minutes of inactivity. The indicator light will blink once every several seconds while the unit is in sleep mode.

Press any button to wake the unit from sleep mode.

Note:



The unit will not enter sleep mode while on the charging dock. The sleep time is over 12 hours automatic shutdown

Instructions

Scheduled Cleaning

You can schedule a time for the unit to start cleaning from Mi Home app. The main unit will automatically start cleaning at the designated times and automatically return to charge at the charging dock when finished.

Resetting the Wi-Fi

Should your mobile phone be unable to connect to the unit due to the configuration of the router, the loss of a password, and so on, then please open its upper cover to see the Wi-Fi indicator while holding down the button  and button  until a voice says 'Resetting Wi-Fi'. Wait until the Wi-Fi indicator slowly blinks red, which indicates a reset has occurred.

Cleaning Modes

You can select Quiet, Standard, and Strong cleaning modes from Mi Home app. The default mode is Standard.

Do Not Disturb Mode

The unit will not automatically start another cleaning task or play any audio while in 'Do Not Disturb' and the indicator light will also be dimmed. The factory settings that come with the device have the hours 22:00-08:00 configured as a 'Do Not Disturb' period. You can turn off Do Not Disturb or modify its hours with Mi Home app.

Instructions

Charging Dock

Place the charging dock against the wall and level on the ground. Ensure 0.5 meters or more space on either side of the charging dock and 1 meter or more in front before connecting it to the power socket. Please ensure that the charging dock is in range of Wi-Fi for a better mobile experience.

Note: Ensure that you do not place the charging dock in an area that receives much sunlight or where there are any other objects that may block the dock's identification zone or it may negatively affect the unit's ability to return to the dock.

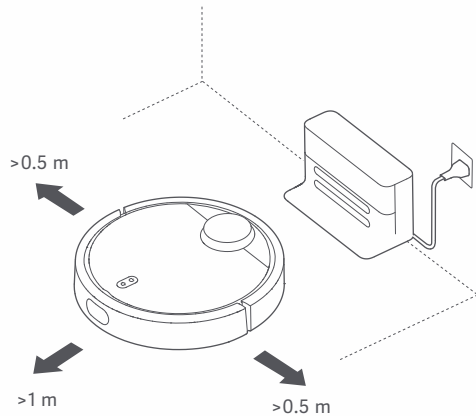

Daily Maintenance

Main Brush* It is recommended that you clean it once a week

1. Flip the device over and remove the main brush cover by holding down the clip.
2. Pull the main brush up and clean the main brush axle.
3. Use the accessory main brush cleaner to remove any tangled hairs on the main brush.
4. Reinstall the main brush. Fix the clip back by applying pressure to the cover.

Note: It is recommended that you replace the main brush every 6-12 months for optimal cleaning effectiveness.

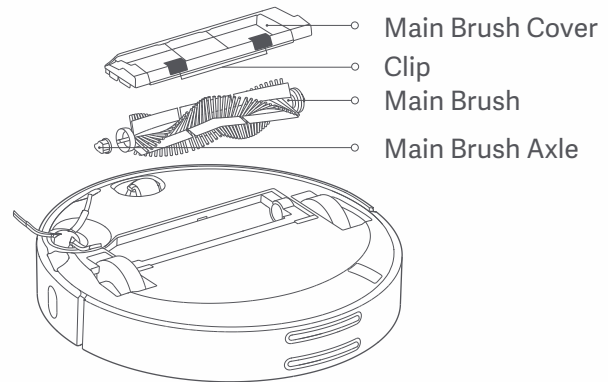

Daily Maintenance

Using the Main Brush Cleaner

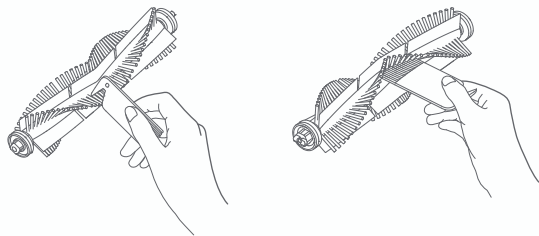

Dust Bin and Filter

* It is recommended that you clean it once per week

1. Open the unit's upper cover and press the bin clip to pull up the dust bin.

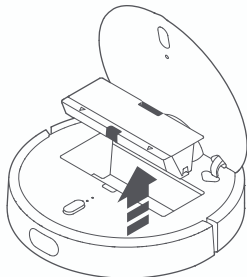

2. Open the bin cover at the location indicated by the arrow.

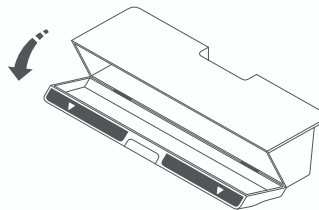

3. Empty out the rubbish contained within.

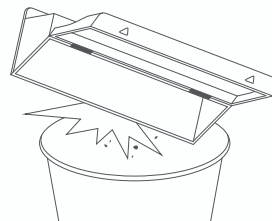

Note: Give the dust bin a light knock when emptying its contents to help prevent the filter from getting blocked.

Daily Maintenance

The filter cannot be rinsed without potentially introducing new obstructions which will affect its cleaning effectiveness.

Note: It is recommended that you replace the filter once every three months for optimal cleaning effectiveness.

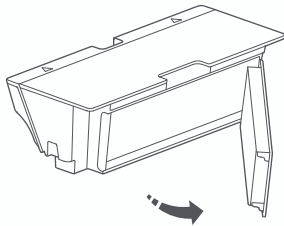

Replace and remove the filter as shown in the figure

Battery

The unit contains a high-performance lithium-ion battery. Please ensure that the device remains well-charged in the course of its everyday use to maintain optimal battery performance

Note: Turn off and set the unit aside if you do not plan on using it for an extended period.

The device should be charged at least once every three months to avoid long-term performance loss.

Side Brush* It is recommended that you clean it every month

1. Flip the device over and remove the fixed side brush screws.
2. Pull out and clean the side brush.
3. Reinstall and tighten up the screws.

Note: It is recommended that you replace the side brush every 3-6 months for optimal cleaning effectiveness.

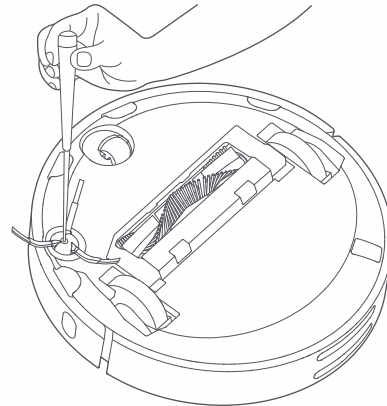

Daily Maintenance

Omnidirectional Wheel

1. Flip the device over and pull up the omnidirectional wheel.
2. Clean hairs, dirt and any other impediments on the wheel and axle.
3. Reinstall the wheel and press down until it is firmly in place.

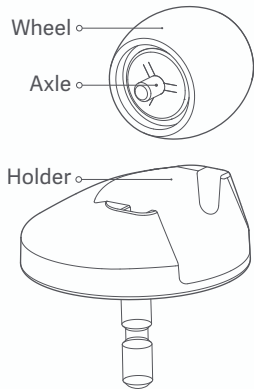

Unit Sensor

It is recommended that you clean it every month

Use a soft cloth to clean all of the unit's sensors, including;

1. Four cliff sensors at the bottom of the unit;
2. The wall sensors on the right side of the unit;
3. The charging contacts at the tail end of the unit.

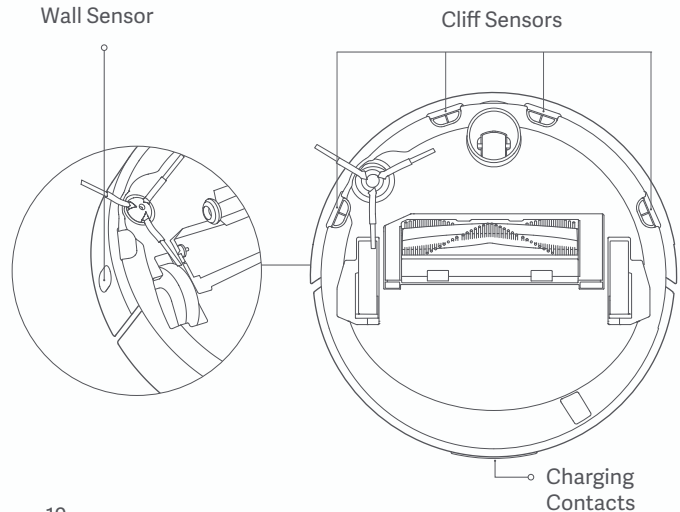

Daily Maintenance

Charging Dock

It is recommended that you clean it every month
Clean the charging dock's coil with a soft cloth.

Firmware Upgrades

You can upgrade the unit's firmware with your Mi Home app.

Please connect the unit to the charging dock and ensure that it has more than 20% power before upgrading.

The indicator light will blink white during the firmware upgrade.

Resetting the System

Try resetting the system if the unit stops responding and cannot be turned off. Press the system reset button (see page 2 for more details) and the unit will automatically restart.

 A system reset will wipe the unit's scheduled cleaning and cleaning mode settings, and also reset the Wi-Fi settings.

Restore Factory Settings

Should a system reset prove ineffective at restoring the device's normal operations, then press the system reset button while holding the button  while the unit is turned on until you hear a voice prompt say 'Restoring to Initial Version'

Specifications

Main unit

Name	Specifications
Dimensions	345×345×96mm
Battery	14.4V/5200mAh lithium battery
Weight	approx.3.8 kg
Wireless connectivity	Wi-Fi SmartConnect support
Rated voltage	14.4V DC
Rated power	55W

Charging Dock

Name	Specifications
Dimensions	230×109×129mm
Rated power	55W
Rated input	100-240V~
Rated output	20V DC 2.2A
Rated frequency	50-60Hz

Troubleshooting

Please refer to the following table when the unit's indicator light is blinking red followed by a voice prompt when it encounters a problem.

Fault Prompt	Solutions
Error 1: Toggle the orange laser head to confirm that it is not obstructed or jammed	The laser distance sensor is stuck due to an obstruction or foreign object. Remove the obstruction or object; if this does not resolve the problem, then move the unit to a new location and activate it.
Error 2: Clean and gently tap on the collision buffer	The collision buffer is stuck. Gently tap on it to remove impediments; if there no impediments, then move the device to a new location and activate it.
Error 3: Move the unit to a new location and activate it	A wheel is in the air. Move the unit to a new location and activate it.
Error 4: Wipe the cliff sensor and activate the device at a distance from the edge	Part of the unit is in the air. Move the device to a new location and activate it; this fault may also occur if the cliff sensor is too dirty. Wipe the cliff sensor to exclude this possibility.
Error 5: Remove the main brush, and clean the bristles and axle	Foreign objects may have become entangled with the main brush. Remove and clean the main brush and axles.
Error 6: Disassemble and clean the side brush	Foreign objects may have become entangled with the side brush. Disassemble and clean the side brush.
Error 7: Check whether the main wheel has caught on any foreign objects and then move it to a new location and activate it	Foreign objects may have become entangled with the main wheel. Please reactivate the device after cleaning the wheel.
Error 8: Clear any obstructions from around the unit	The unit may be caught or stuck. Please clear away any obstructions around the device.
Error 9: Reinstall the dust bin and filter	Reinstall the dust bin and filter and confirm that the filter and dust bin are installed correctly; should this error continue after the filter and dust bin have been installed correctly, then try replacing the filter.

Troubleshooting

Error 10: Clean or replace the filter	The filter may be obstructed. Clean and replace the filter if you are still unable to solve the problem.
Error 11: Check whether there are any strong magnetic fields present and restart the device at a distance from any virtual walls	The unit has been activated too close to the virtual wall. Move it to a new location and then activate it.
Error 12: There is not enough power. Recharge the device	There is not enough power. Recharge the device and then use it.
Error 13: There is a charging error. Try cleaning the device's charging area	Wipe the unit's charging contacts and charging dock coil with a cloth.
Error 14: There is a battery problem	The temperature of the battery is too high or too low. Wait for the temperature to return to normal and then reuse the device.
Error 15: Wipe the wall sensor	The wall sensor has been obstructed by particulates. Wipe the wall sensor.
Error 16: Place the unit on level ground and then activate it	The unit has detected that it is at an angle on activation. Restart it after placing the device on level ground.
Error 17: There is a problem with the side brush module. Try resetting the system	The side brush module cannot operate normally. Try resetting the system.
Error 18: There is something wrong with vacuum's suction fan. Try resetting the system	The suction fan cannot operate normally. Try resetting the system.
Error 19: The power is not coming through the charging dock. Confirm that the power cord is correctly plugged in	The charging dock power cord may not be correctly plugged in. Try charging it again after confirming that the power cord is correctly inserted.
There is an internal error. Try resetting the system	The unit detects that there is an internal error and it cannot continue operating. Try resetting the system.

Note: Resetting the system will resolve some problems

FAQ

Problem Type	Solutions
It can't turn on	There is not enough power. Try turning the device on again after recharging it on the charging dock.
It can't charge	Power is not being provided through the charging dock. Confirm that both ends of the charging dock's power cable are inserted correctly. Clean the charging dock coil and the unit's charging contacts should there be an issue with the contact surfaces.
It can't recharge	There are too many obstructions around the charging dock. Place the charging dock in a more open area.
Execution Problems	Turn the device off and then restart it;
There is a strange sound when the device is cleaning	Foreign objects may have become entangled with the main brush, side brush or wheel. Stop and clean the device.
The device's cleaning has become less effective or it leaves dust behind.	The dust bin is full. Clean the dust bin. The filter is blocked. Clean the filter. Objects may have become entangled with the main brush. Clean the main brush.
It can't connect to Wi-Fi	The Wi-Fi signal is weak. Please ensure that the unit is in an area with good Wi-Fi coverage.
Scheduled cleaning does not occur	There is not enough power. The device will only start scheduled cleaning when it has more than 20% power remaining.
Does consistently leaving the device on the charging dock consume power?	Consistently leaving the unit on the charging dock will consume a very small amount of power, and it is helpful for maintaining its optimal battery performance.
Does the device need to be fully charged for 16 hours the first three times it is used?	Lithium batteries do not suffer from 'memory effects' and can be recharged at will. There is no need to wait for 16 hours before using the device after it is fully charged.

Performance failure list of robot vacuum

Performance failure list of robot vacuum	
Name	Performance failure
Main unit	Function failure listed in the User Manual
	Cannot power on
	Main brush inoperative, side brush inoperative
Charging dock	Cannot power the machine
Power Cord	Cannot power the dock charger

EU Declaration of Conformity

Hereby we:

Name of manufacturer	Beijing Roborock Technology Co., Ltd.
Address	Floor6,Suite6016,6017,6018,BuildingC,Kangjian Baosheng Plaza, No.8 Heiquan Road,Haidian District, Beijing,P.R.CHINA

EU Declaration of Conformity

declare that this DoC is issued under our sole responsibility and that the products:

Product description	Mi Robot Vacuum and Accessories
Type(model) designation(s)	SDJQR02RR

are in conformity and verified through testing with the provision of the following EU directives:

RED Directive 2014/53/EU Article 3.1 a): Safety&Health 1. EN 60335-1:2012 + A11:2014 + AC:2014 2. EN 60335-2-2:2010 + A11:2012 + A1:2013 3. 1999/519/EC 4. EN 62311:2008 5. EN 62233:2008	1.Household and similar electrical appliances-Safety-Part 1: General requirements 2.Household and similar electrical appliances-Safety-Part 2-2: Particular requirements for vacuum cleaners and water suction cleaning appliance 3.COUNCIL RECOMMENDATION of 12 July 1999 on the limitation of exposure of the general public to electromagnetic fields (0 Hz to 300 GHz) 4.Assessment of electronic and electrical equipment related to human exposure restrictions for electromagnetic fields (0 Hz - 300 GHz) 5.Measurement methods for electromagnetic fields of household appliance and similar apparatus with regard to human exposure
-------------------------------------------------------------------------------------------------------------------------------------------------------------------------------------------------------------	-----------------------------------------------------------------------------------------------------------------------------------------------------------------------------------------------------------------------------------------------------------------------------------------------------------------------------------------------------------------------------------------------------------------------------------------------------------------------------------------------------------------------------------------------------------------------------------------------------------------------------------------------------------

EU Declaration of Conformity

<p>RED Directive 2014/53/EU Article 3.1 b): EMC</p> <ol style="list-style-type: none"> 1. Draft EN301 489-1 V2.2.0: 2. Draft EN 301 489-17 V3.2.0: 3. EN 55014-1:2006/+A1:2009/+A2:2011 4. EN 55014-2: 2015 5. EN 61000-3-2: 2014 6. EN 61000-3-3: 2013 	<ol style="list-style-type: none"> 1. Electromagnetic Compatibility (EMC) standard for radio equipment and services; Part 1: Common technical requirements; Harmonized Standard covering the essential requirements of article 3.1(b) of Directive 2014/53/EU and the essential requirements of article 6 of Directive 2014/30/EU 2. Electromagnetic Compatibility (EMC) standard for radio equipment and services; Part 17: Specific conditions for Broadband Data Transmission Systems; Harmonized Standard covering the essential requirements of article 3.1(b) of Directive 2014/53/EU 3. Electromagnetic Compatibility-Requirements for household appliances, electric tools and similar apparatus Part 1: Emission 4. Electromagnetic compatibility – Requirements for household appliances, electric tools and similar apparatus Part 2: Immunity – Product family standard 5. Electromagnetic compatibility (EMC) - Part 3-2: Limits - Limits for harmonic current emissions (equipment input current ≤ 16 A per phase). 6. Electromagnetic compatibility (EMC) - Part 3-3: Limits - Limitation of voltage changes, voltage fluctuations and flicker in public low-voltage supply systems, for equipment with rated current ≤ 16 A per phase and not subject to conditional connection.
<p>RED Directive 2014/53/EU Article 3.2: Radio Spectrum EN 300 328 V2.1.1</p>	<p>Wideband transmission systems; Data transmission equipment operating in the 2,4 GHz ISM band and using wide band modulation techniques; Harmonized Standard covering the essential requirements of article 3.2 of Directive 2014/53/EU</p>
<p>ROHS Directive 2011/65/EU EN 62321: 2009</p>	<p>Electro technical products – Determination of levels of six regulated substances (lead, mercury, cadmium, hexavalent chromium, polybrominated biphenyls, polybrominated diphenyl ethers)</p>

EU Declaration of Conformity

Product description	Charging Dock and Accessories
Type(model) designation(s)	Charging Dock, models: CDZ05RR.

are in conformity and verified through testing with the provision of the following EU directives:

<p>Low Voltage Directive 2014/35/EU</p> <ol style="list-style-type: none"> 1. EN 60335-1:2012 + A11:2014 2. EN 60335-2-29:2004 + A2:2009 3. EN 62233:2008 	<ol style="list-style-type: none"> 1. Household and similar electrical appliances-Safety-Part 1: General requirements 2. Household and similar electrical appliances-Safety-Part 2-29: Particular requirements for battery chargers 3. Measurement methods for electromagnetic fields of household appliance and similar apparatus with regard to human exposure
<p>EMC Directive 2014/30/EU</p> <ol style="list-style-type: none"> 1. EN 55014-1:2006/+A1:2009/+A2:2011 2. EN 55014-2: 2015 3. EN 61000-3-2: 2014 4. EN 61000-3-3: 2013 	<ol style="list-style-type: none"> 1. Electromagnetic Compatibility-Requirements for household appliances, electric tools and similar apparatus Part 1: Emission 2. Electromagnetic compatibility – Requirements for household appliances, electric tools and similar apparatus Part 2: Immunity – Product family standard 3. Electromagnetic compatibility (EMC) - Part 3-2: Limits - Limits for harmonic current emissions (equipment input current ≤ 16 A per phase). 4. Electromagnetic compatibility (EMC) - Part 3-3: Limits - Limitation of voltage changes, voltage fluctuations and flicker in public low-voltage supply systems, for equipment with rated current ≤ 16 A per phase
<p>ROHS Directive 2011/65/EU</p> <p>EN 62321: 2009</p>	<p>Electro technical products – Determination of levels of six regulated substances(lead, mercury, cadmium, hexavalent chromium, polybrominated biphenyls, polybrominated diphenyl ethers)</p>

EU Declaration of Conformity

Person responsible for making this declaration:

Printed name: Rui.Shen

Position/Title: Quality Director

Signature: Rui.Shen.

Date of issue: Nov 2, 2017



Mi Robot Vacuum

Manufactured for : Xiaomi Communications Co., Ltd.

Manufactured by : Beijing Roborock Technology Co., Ltd.

Model : SDJQR02RR

Address : Room 6016, 6017, 6018, Building C, Baosheng Plaza, No. 8, Heiquan Road, Haidian District, Beijing 100192, China