

Specifications

SMART Board[®] E70 interactive flat panel

Model SPNL-4070

Overview

Designed specifically for classrooms, the SMART Board[®] E70 interactive flat panel combines a premium touch experience with the power of SMART Notebook[™] collaborative learning software on a 177.8cm (70") display.

The high-definition, shadow-free LED display features low-friction coated glass that enables fingers to glide smoothly over the surface, facilitating a natural touch experience. The SMART Board E70 interactive flat panel virtually eliminates glare and provides an optimal view from any angle in the classroom, delivering an unparalleled viewing and writing experience for the best value for classrooms. The multitouch SMART Board E70 interactive flat panel features freestyle multi-user interaction anywhere on the display with Windows[®] 7 or Windows 8 operating systems, enabling students to collaborate without limitations.

See smarttech.com for more information on this product.

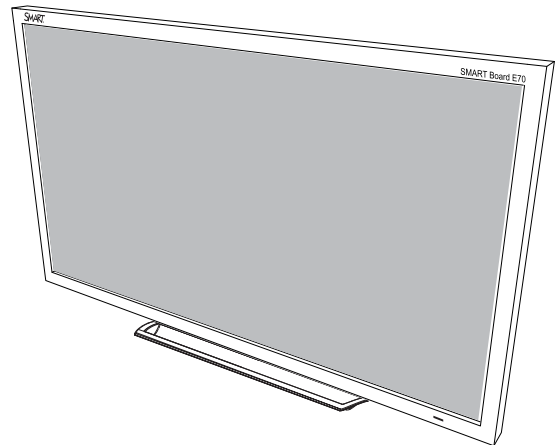

SPECIFICATIONS

SMART Board E70 interactive flat panel – Model SPNL-4070

Dimensions and weights¹

Dimensions

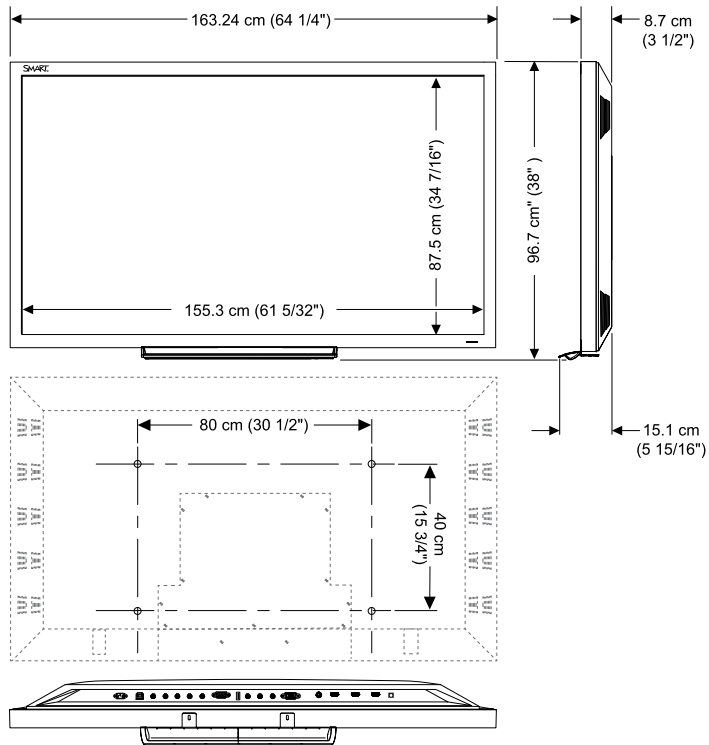

Dispatch dimensions

1 unit on a pallet

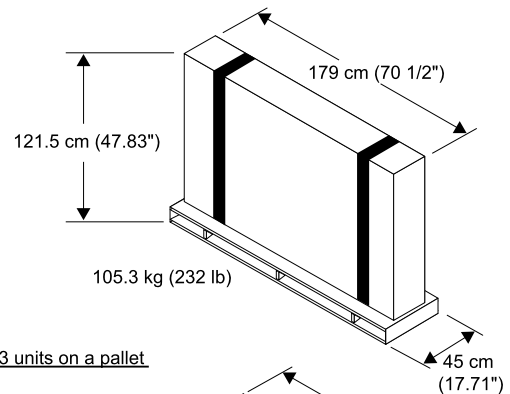

3 units on a pallet

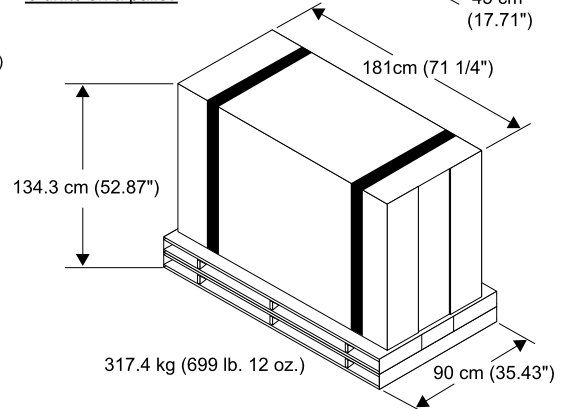

Weight

77kg (169 lb 13oz)

General specifications

Touch technology

Infrared

Multitouch capabilities

Eight touch on computers with Windows 7 or Windows 8 operating systems.

Gestures

Supports gestures on Windows 7, Windows 8, Mac OS X 10.7 or Mac OS X 10.8 operating systems software.

Horizontal frequency

30–91 kHz

Vertical frequency

50–85 Hz

Contrast ratio (typical)

4000:1

Brightness (typical)

350 cd/m²

Optimum resolution

1920 × 1080p at 60 Hz (16:9)

Audio

Two 10 watt speakers

¹All dimensions ± 0.3cm (1/8"). All weights ± 0.9kg (2lb)

Accessories

Pens and pen tray	Two ergonomic pens with comfort grip and a pen tray
Power cable	North America, Europe and UK
Remote control	One remote control
VGA cable	1.8m (6') D-sub 15-pin connector
USB cable (touch)	5m (16') USB A/B

Connections

HDMI™	Three HDMI inputs
RGB D-sub (VGA)	D-sub 15-pin inputs
Component	5 RCA inputs (Y, Pb, Pr, L, R)
Composite	RCA analogue audio and composite video inputs (red, white, yellow)
SPDIF	SPDIF optical output
USB	USB A (to access media files) and USB B (touch)
PC audio	3.5 mm stereo input
AC power	IEC 60320-C14 socket

Computer requirements

SMART Board E70	A computer with either a Windows 7, Windows 8, Mac OS X 10.7 or Mac OS X 10.8 operating system software and SMART Notebook™ collaborative learning software 11.3 or above installed. For a complete list of computer requirements, see the SMART Notebook software release notes available at smarttech.com/downloads .
------------------------	--

Operating and storage requirements

Power supply	100 V AC–240 V AC, 50/60 Hz
Power consumption	280 W max
Standby Power	< 0.5 W
Operating temperature	10°C–40°C (50°F–104°F)
Operating humidity	10%–80%, non-condensing
Storage temperature	-25°C–60°C (-13°F–140°F)
Storage humidity	5%–95%, non-condensing

SPECIFICATIONS

SMART Board E70 interactive flat panel – Model SPNL-4070

Certification and compliance

Regulatory certification UL/c-UL (US and Canada), FCC, IC and CE

Environmental compliance

European Union REACH, RoHS, WEEE, Battery, Packaging and ErP Standby

US Packaging and Conflict Minerals

Warranty

SMART Board E70 Two-year limited equipment warranty. A three-year warranty extension is also available. Contact your authorised SMART reseller for more information.

Purchasing information

Order numbers

SPNL-4070 SMART Board E70 interactive flat panel. Includes a SMART Notebook software installation DVD.

Optional accessories For more information on additional accessories for your SMART Board E70 interactive flat panel, see smarttech.com/accessories.

smarttech.com/support
smarttech.com/contactsupport

© 2013 – SMART Technologies ULC. All rights reserved. SMART Board, SMART Notebook, smarttech, the SMART logo and all SMART taglines are trade-marks or registered trade-marks of SMART Technologies ULC in the US and/or other countries. Windows is either a registered trademark or a trademark of Microsoft Corporation in the U.S. and/or other countries. All other third-party product and company names may be trade-marks of their respective owners. This product and/or use thereof covered by one or more of the following US patents. www.smarttech.com/patents. Contents are subject to change without notice. 01/2014.